

# WP525

## Imaging Spectral Colorimeter



The only all-in-one tristimulus imaging spectral colorimeter

### Description

The WP525 is a unique imaging colorimeter solution comprising an integrated 24.6 MP, tristimulus-filtered camera and an internal reference spectroradiometer. As a result, the WP525 has superb performance without the hassle and cost of multiple discrete instruments. Everything needed is in one compact package, and the included Photometrica<sup>®</sup> software features all the tools required to characterize displays and lighting efficiently.

### All display types and sizes

With a wide assortment of lenses available, from microscope objectives to wide-angle, the WP525 is configurable for measurements of any display size, from microdisplays to smartwatches, tablets, TVs, or cinema walls. The system supports electronic or manual lenses from 24 to 100 mm focal length, and fixed focus microscope lenses up to 10X magnification. In addition, our Conometer<sup>®</sup> Viewing Angle Lens for measurements, and the XR1 Near Eye Display Lens for analysis of augmented and virtual reality displays are available.

### Key Features

- 24.6 MP imaging
- XYZ tristimulus filters
- Integrated spot spectroradiometer
- 0.0006 cd/m<sup>2</sup> sensitivity
- No polarization error
- Automatic dark measurements
- EF lenses
- No beam splitter

### Applications

- Flat panel displays
- Near eye displays
- Lighting
- LED arrays

wphotonics.com

# WP525 Imaging Spectral Colorimeter

## Description

Key to the WP525's unique capability is the high-speed linear translation stage. The stage has multiple positions for imaging light with the spectroradiometer or with the  $X_{Red}$ ,  $X_{Blue}$ , Y and Z tristimulus filters and camera. In addition, there is standard filtering up to ND2 in the spectrometer path.

Conveniently, the moving stage also provides positions where the imager or spectrometer is shuttered from illumination. Dark measurements to correct detector noise are fully automated.

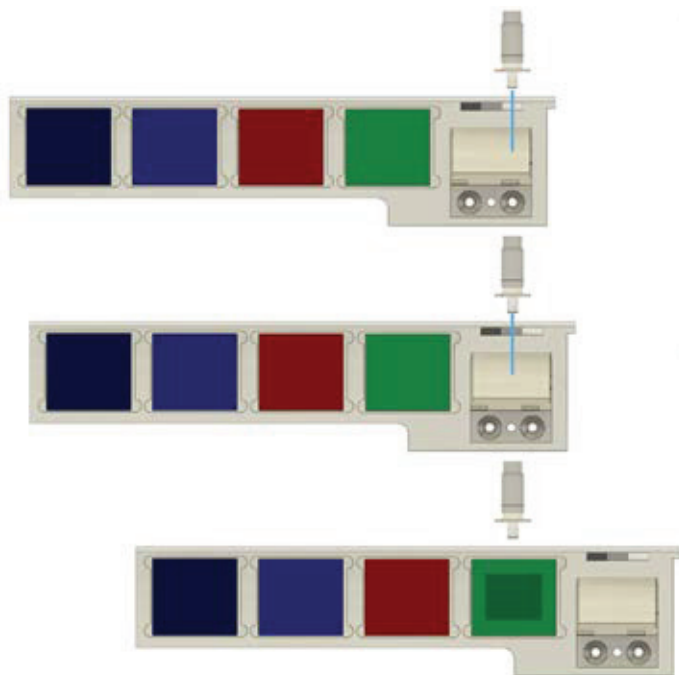

Illustration: The fiber is fixed, and the stage moves left and right.

Top: a prism blocks the imager and deflects light to the fiber through an ND0 filter.

Middle: the prism deflects light through a ND1 filter.

Bottom: a tristimulus filter in front of the imager.

## Measure and correct all colors

The tristimulus-filtered imager provides accurate color measurements. However, the spectroradiometer can be much better. For example, the imager accuracy can be improved by 2x to 10x when measuring white or monochrome LEDs when correcting with the internal reference spectroradiometer. Making color corrections with the integrated spot spectroradiometer is fast and automatic.

## AR/VR display testing

The periscope design [XR1 Near Eye Display \(NED\) Lens](#) provides optimal test performance for augmented and virtual reality displays. The periscope design ensures the lens readily fits into final assemblies of glasses, headsets, and helmets. Under different stimuli, human visual accommodation results in varying pupil diameters. Applications benefit from an entrance pupil that is adjustable from 1.5 to 5.0 mm.



## Distortion corrected

A menu-driven registration and distortion correction assistant allows users to correct for lens distortions. Once the correction is applied, any distortions in the display under test are revealed and can be analyzed.

## Viewing angle

The [Conometer Lens](#) enables viewing angle measurements of flat panel displays and backlights up to  $\pm 80^\circ$ .



## Spectral performance

The integrated, low-noise CMOS spectrometer is optimized for color measurements. The combination of low optical stray light and high dynamic range using exposure time stacking enables superb color measurements.

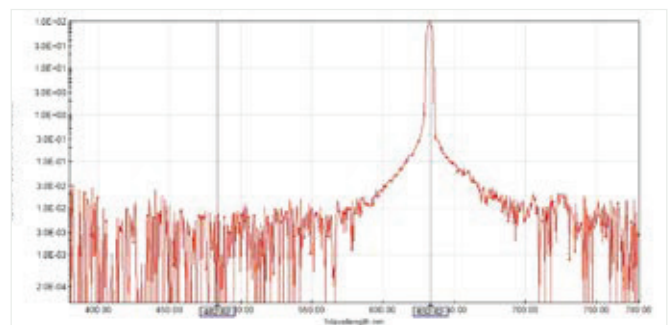

HeNe laser spectrum plotted in log scale showing  $<1E-4$  stray light

## Comprehensive solution for production testing

The WP525 has all the right features for deployment in production applications:

- The precision mechanics are rated for two million color and spectral measurements before maintenance is required.
- The high-accuracy spectroradiometer and camera have hardware triggers to synchronize the measurement with other equipment in the test setup.
- The camera uses advanced thermal management to keep the sensor cool and sensitive.
- Air filters attached to the fan vents to help keep dust out of the electronics area.
- Westboro Photonics also offers on-site recalibration software to minimize production downtime and other costs related to off-site calibration.
- Westboro Photonics' network of international distributors and local recalibration labs provide additional support.

## Flat panel display testing

With our comprehensive display performance and defect tests, users can readily deploy solutions to production with minimal engineering effort. Performance tests include uniformity, gamma, gamut, contrast, and viewing angle. Defect tests include pixel and line defects, mura, dust, debris, etc.

## Versatility for many applications

Westboro Photonics also offers specialized add-on software packages to help with specific tests, e.g., [Uniformity](#), [Graphics](#), [Styling Line](#), [Beam Pattern](#), [Head Up Display](#), and more.

## How can I learn more?

Visit our website for more information about our latest products and [Photometrica software](#) capabilities to measure and analyze displays, lighting and more.

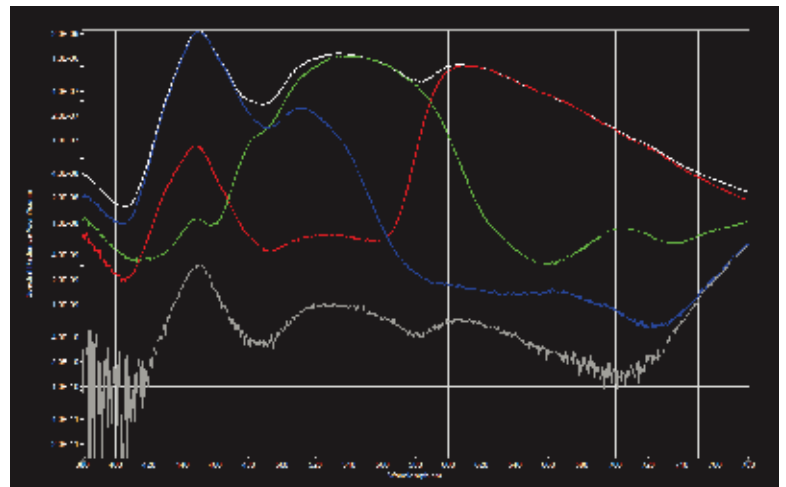

Photometrica software windows showing an example of the display surface pseudo color mapped to luminance, and spectral data in log scale from the measurement spot for white, red, green and blue display settings.

# WP525 Imaging Spectral Colorimeter

| TECHNICAL SPECIFICATIONS*   |                    |  |
|---|--------------------|--|
| 2D measurements   |                    | Luminance, chromaticity                          |
| Spectral spot measurements  |                    | Spectrum, luminance, chromaticity, radiance etc. |
| IMAGER  |                    |  |
| Resolution  |                    | 4608 (H) × 5328 (V) (24.6 MP)                    |
| Pixel size  |                    | 2.74 μm x 2.74 μm                                |
| Dynamic range   |                    | >1 000 000:1                                     |
| Luminance minimum 2D  | Limit of detection | 0.0006 cd/m <sup>2</sup>                         |
|   | SNR = 60           | 0.01 cd/m <sup>2</sup>                           |
|   | SNR = 100          | 0.015 cd/m <sup>2</sup>                          |
| Luminance maximum without optional ND filters (cd/m <sup>2</sup> ) <sup>2</sup> |                    | 360 000 cd/m <sup>2</sup>                        |
| Precision <sup>3</sup> for luminance and chromaticity                           |                    | ±0.05% for Y; ±0.00004 for u', v'                |
| SPECTRORADIOMETER   |                    |  |
| Wavelength range  |                    | 380-780 nm                                       |
| Resolution bandpass   |                    | 4.2 nm   |
| Data point interval   |                    | 0.57 nm  |
| Wavelength accuracy   |                    | 0.5 nm   |
| Stray light, 8 bandwidths from HeNe laser                                       |                    | 3 E-5  |
| Spectral spot area; diameter  |                    | ~38 000 pixels; 220 pixels                       |
| Luminance range <sup>4</sup>  |                    | 0.06 - 120 000 cd/m <sup>2</sup>                 |
| Precision <sup>3</sup> for luminance and chromaticity                           |                    | ±0.1 % for Y; ±0.0001 for u', v'                 |
| Accuracy of spot spectroradiometer <sup>5</sup>                                 |                    | ±3.5% for Y; ±0.0015 for u', v'                  |
| Polarization sensitivity <sup>6</sup>   |                    | ±0.1% for Y; ±0.0001 for u', v'                  |
| MEASUREMENT TIME <sup>7</sup>   |                    |  |
| 2D color (XYZ) + spectrum   |                    | 7.9 s  |
| 2D color (XYZ)  |                    | 7.2 s  |
| 2D luminance (Y) only   |                    | 0.6 s  |
| Spectrum only   |                    | 0.3 s  |
| GENERAL   |                    |  |
| Operating System  |                    | Windows 10/11 (64 bit)                           |
| Dimensions (l x w x h) <sup>8</sup>   |                    | 190 mm x 190 mm x 100 mm                         |
| Height of optical axis above camera mount                                       |                    | 102 mm   |
| Interface   |                    | USB3, Gigabit Ethernet                           |
| Weight  | WP525              | 4.1 kg   |
|   | WP525-01           | 3.6 kg   |
| Power supply  |                    | 12 V, 4A max                                     |
| Operating temperature range   |                    | 15 – 35°C, 0-85% humidity, non-condensing        |

| ORDERING SPECIFICATIONS                 |            |        |     |
|---|------------|--------|-----|
| OPTIONS                                 |            |        |     |
| WP525 Imaging Spectral Colorimeter      |            |        |     |
| WP525-01 Imaging Colorimeter            |            |        |     |
| STANDARD LENSES                         | ELECTRONIC | MANUAL | ND  |
| 14 mm                                   | N/A        | ✓      | N/A |
| 24 mm                                   | ✓          | ✓      | ✓   |
| 35 mm                                   | ✓          | ✓      | ✓   |
| 50 mm                                   | ✓          | ✓      | ✓   |
| 100 mm macro                            | ✓          | ✓      | ✓   |
| SPECIAL LENSES                          |            |        |     |
| 2X microscope                           |            |        |     |
| 5X microscope                           |            |        |     |
| 10X microscope                          |            |        |     |
| <a href="#">XR1 Near Eye Display</a>    |            |        |     |
| <a href="#">Conometer Viewing Angle</a> |            |        |     |

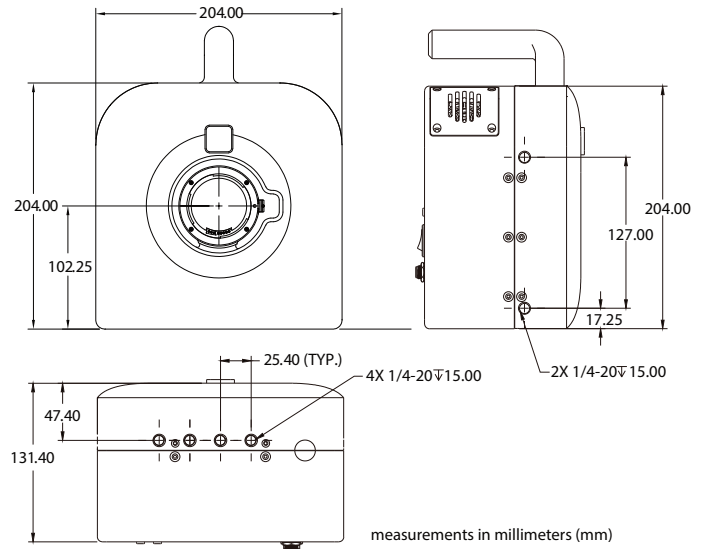

\* Unless stated otherwise, specifications are for a 189 pixel diameter spot in the center of the image, 50 mm lens at iris F1.2 to F11, at 1 m focus distance, and measuring illuminant A. Accuracy and precision specifications are at 23°C +/- 2°C after calibration and after 30 minutes of warmup. Specifications are subject to change.

- Luminance minimum: Using exposure times of 8.52 s and a 500 x 500 pixel area on axis. Limit of detection is SNR = 3.
- Luminance maximum: Using exposure times of 0.52 ms and iris setting of F11.3.
- 2 σ deviation for repeat measurements (Y ≈ 100 cd/m<sup>2</sup> using auto single or auto-HDR captures).
- Using exposure times from 8 ms to 2 s, averaging, internal ND0 and ND1, iris settings of F2.8 and F11.3, and SNR = 10.
- Immediately after calibration and relative to standard for measurements with HDR and adequate signal-to-noise.
- Maximum deviation from average when measuring broadband, linear polarized light at varying polarization angles.
- Times are for the full image, using minimum exposure times and a fast PC.
- Excluding lens and handle.

Westboro Photonics continually pursues improvements to the instruments. Specification adjustments, errata or omissions do not constitute grounds for compensation.



Suite 301, 1505 Carling Ave  
Ottawa, Ontario  
K1Z 7L9 Canada

Phone: +1.613.729.0614  
Email: info@wphotonics.com  
www.wphotonics.com

01/24



(주) 래디언트솔루션 Tel: 02-2065-0726  
Email: cs@radiantsolution.co.kr

**Radiant Solution**  
Excellence In Optical Measurement